

Trusted. Tested. Tough.®



SECTION: 2.30.030

FM2851

0821

Supersedes

1020

Product information presented here reflects conditions at time of publication. Consult factory regarding discrepancies or inconsistencies.

Patent No. 8,535,014  
Automatic model only

## TECHNICAL DATA SHEET

**EXPLOSION PROOF OR DUST-IGNITION PROOF RATED SERIES\***  
 Models X282 & X284 Submersible Sewage Pumps For Hazardous Locations  
 Class I, Division 1, Groups C & D Rated and Class I, Zone 1, Groups IIA & IIB Gas Areas  
 or  
 Class II, Division 1, Groups E, F & G and Zone 20 Dust Areas

### PRODUCT SPECIFICATIONS

<b>MOTOR</b>	Horse Power	1/2 (X282) or 1 (X284)
	Voltage	115 - 575
	Phase	1 or 3 Ph
	Hertz	60 Hz
	RPM	1750
	Type	Permanent split capacitor or 3 Ph
	Insulation	Class B
	Amps	1.4 - 10.3
<b>PUMP</b>	Operation	Automatic or nonautomatic
	Auto On/Off Points	19-3/4" (50.2 cm) / 10" (25.4 cm)
	Discharge Size	2" or 3" NPT female, flanged vertical
	Solids Handling	2" (50 mm) spherical solids
	Cord Length	20' (6 m) standard
	Cord Type	UL listed 5-wire (1 Ph) or 8-wire (3 Ph) SOOW
	Max. Head	35' (10.7 m)
	Max. Flow Rate	179 GPM (678 LPM)
	Max. Operating Temp.	104 °F (40 °C)
	Cooling	Oil filled
	Motor Protection	Auto reset thermal overload (1 Ph) or thermal sensor (3 Ph)
<b>MATERIALS</b>	Upper Bearing	Ball bearing
	Lower Bearing	Ball bearing
	Mechanical Seals	Carbon and ceramic w/stainless steel parts
	Impeller Type	Non-clogging vortex
	Impeller	Cast iron
	Hardware	Stainless steel or brass
	Gasket	Neoprene square rings

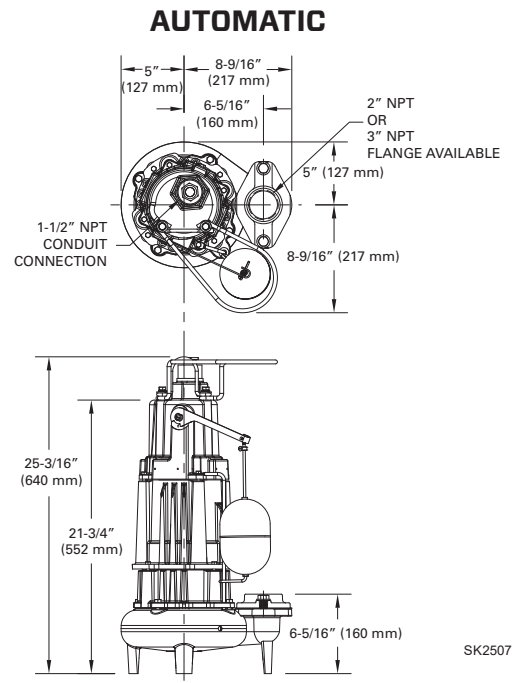

### NONAUTOMATIC

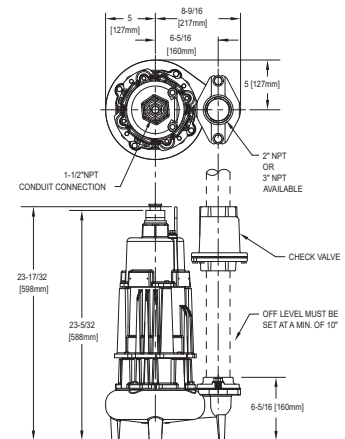

All Class 30 cast iron construction.

NOTE: The sizing of a pump system normally requires variable level float(s) controls and properly sized basins to achieve required pumping cycles or dosing timers with automatic pumps.

NOTE: \*Pump tags will be specific to either gas or dust areas

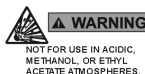

SK1913

**TOTAL DYNAMIC HEAD & FLOW PER MINUTE**

MODELS		X282/X4282		X284/X4284	
Feet	Meters	Gal.	Liters	Gal.	Liters
5	1.5	127	481	179	678
10	3.0	96	363	157	594
15	4.6	64	242	133	503
20	6.1	34	129	106	401
25	7.6	6	23	73	276
30	9.1	--	--	42	159
Shut-off Head		26 ft. (7.9 m)		35 ft. (10.7 m)	

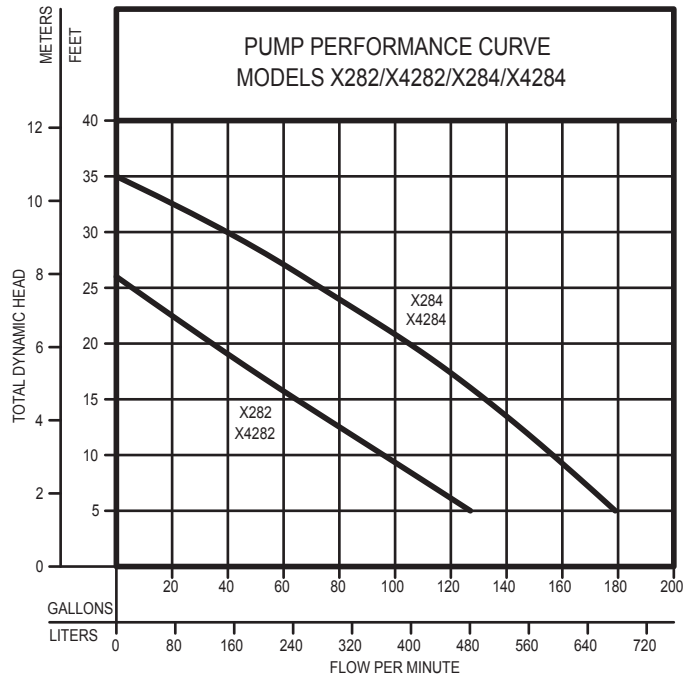

009927

Model	MODEL COMPARISON										
	Seal	*Mode	Volts	Ph	Amps	HP	Hz	Lbs	Kg	Simplex	Duplex
MX282	Single	Auto	115	1	10.3	1/2	60	119	53	3 & 4	---
NX282	Single	Non	115	1	10.3	1/2	60	124	56	1 & 2	1 & 2
DX282	Single	Auto	230	1	5.0	1/2	60	119	53	3 & 4	---
EX282	Single	Non	230	1	5.0	1/2	60	124	56	1 & 2	1 & 2
HX282	Single	Auto	200	1	6.1	1/2	60	119	53	3 & 4	---
IX282	Single	Non	200	1	6.1	1/2	60	127	57	1 & 2	1 & 2
JX282	Single	Non	200	3	3.6	1/2	60	127	57	1 & 2	1 & 2
FX282	Single	Non	230	3	3.0	1/2	60	127	57	1 & 2	1 & 2
GX282	Single	Non	460	3	1.7	1/2	60	127	57	1 & 2	1 & 2
BAX282	Single	Non	575	3	1.4	1/2	60	127	57	1 & 2	1 & 2
DX284	Single	Auto	230	1	8.9	1	60	122	55	3 & 4	---
EX284	Single	Non	230	1	8.9	1	60	124	56	1 & 2	1 & 2
HX284	Single	Auto	200	1	9.3	1	60	122	55	3 & 4	---
IX284	Single	Non	200	1	9.3	1	60	127	57	1 & 2	1 & 2
JX284	Single	Non	200	3	5.5	1	60	127	57	1 & 2	1 & 2
FX284	Single	Non	230	3	5.0	1	60	127	57	1 & 2	1 & 2
GX284	Single	Non	460	3	2.6	1	60	127	57	1 & 2	1 & 2
BAX284	Single	Non	575	3	2.2	1	60	127	57	1 & 2	1 & 2

\*For non-auto models, water level switch is required to be set at a minimal off point of 10 inches to meet dust-ignition proof certification requirements. Additional cord lengths are available in 25' (7.6 m), 35' (11 m) and 50' (15 m). All Models are, cCSAus certified for hazardous gas or dust locations. Tested to FM Standards 3600 & 3615 & 3616 by CSA

**SELECTION GUIDE**

1. See FM1705 for correct intrinsically-safe simplex or duplex panel
2. See FM0526 for variable level control switches rated 30VDC are used as a control activator. Quantity required dependent upon panel selection.
3. Automatic pump with integral float-operated mechanical switch: no external control required
4. Automatic pumps: Use the optional seal-failure panel (10-1031) to activate the moisture sensor circuit for pump protection and when required by local codes

**CAUTION** All installation of controls, protection devices and wiring should be done by a qualified licensed electrician. All electrical and safety codes should be followed including the most recent National Electrical Code (NEC) and the Occupational Safety and Health Act (OSHA).