



Model: **DX-108** Item #: _____ Date: _____
 Project: _____ Qty: _____ Approved By: _____

8" Center Wall Mount Pre-Rinse

DIAMOND
series



DESCRIPTION

8" Center Wall Mount Pre Rinse, Ultra-Polish Satin Finish, 1.15 GPM Dual Spray Head Valve

STANDARD FEATURES

- 1/4 turn stainless steel high performance ceramic cartridge valves with built-in check valves
- Heavy Duty Flanges with eccentric fittings and innovative flange seal
- Dual Spray Technology, 1.15 GPM Knife & Cyclone Options
- Lever Handles
- Adjustable Wall Bracket & mounting kit included
- E-Z install flexible water line kit included
- Lifetime Warranty

SPECIFICATIONS

Water Inlet	1/2" NPT Female
Temp. Range	40°F - 180°F
Pressure	20-120 PSI
Spray Head Flow Rate	1.15 GPM
Body Material	Solid Brass
Finish	Ultra-Polish Satin
Weight	16 lbs.
Dimensions	35" high with 15" Overhang

PRODUCT COMPLIANCE

- ASME A112.18.1/CSA B125.1
- NSF-61
- NSF/ANSI 372
- Meets ANSI A117.1 (ADA)

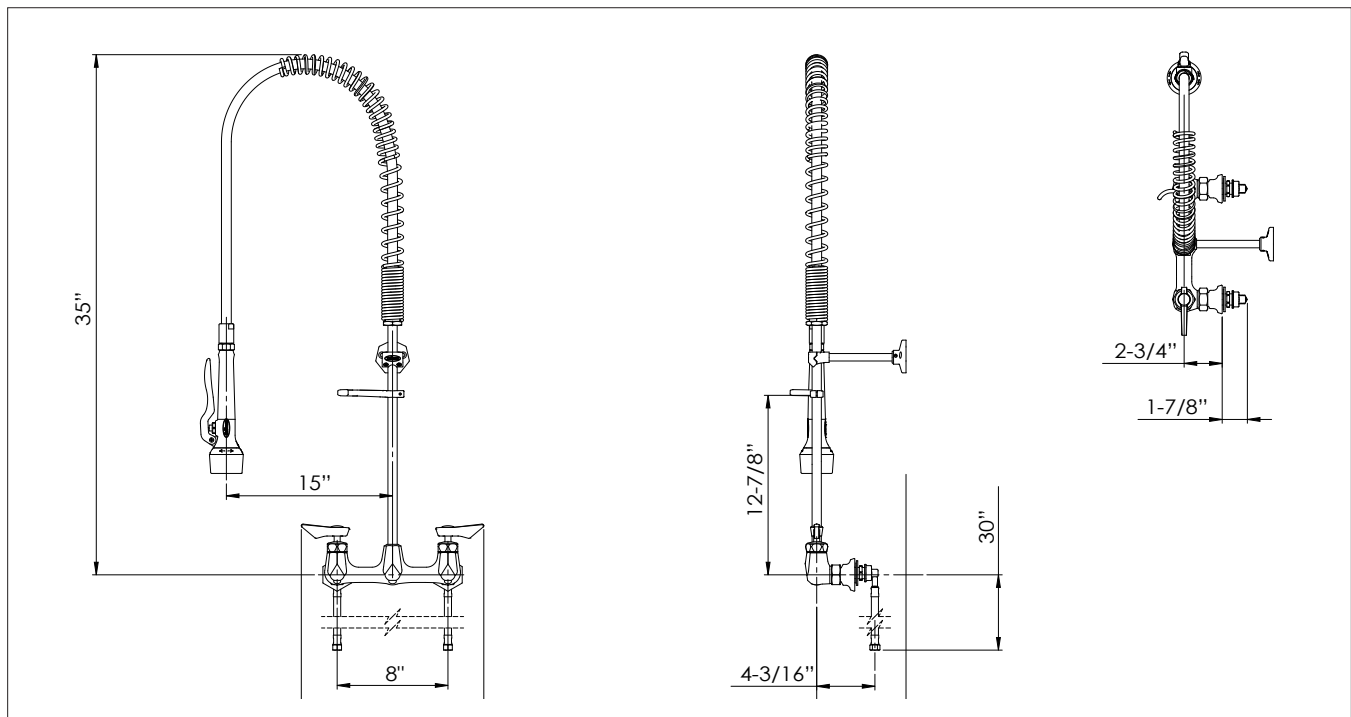

WARNING: Plumbing connections should be made by qualified personnel who will observe all applicable plumbing, sanitary and safety codes.
 California Proposition 65 Warning

Krowne Metal Corporation • 100 Haul Rd. Wayne, NJ 07470 • P: (800) 631-0442 • customerservice@krowne.com • krowne.com

Due to our commitment to continued product improvement, specifications are subject to change without notice.

Rev. 03/2021 • No. DX-108



Model: **DX-108** Item #: _____ Date: _____
 Project: _____ Qty: _____ Approved By: _____

8" Center Wall Mount Pre-Rinse

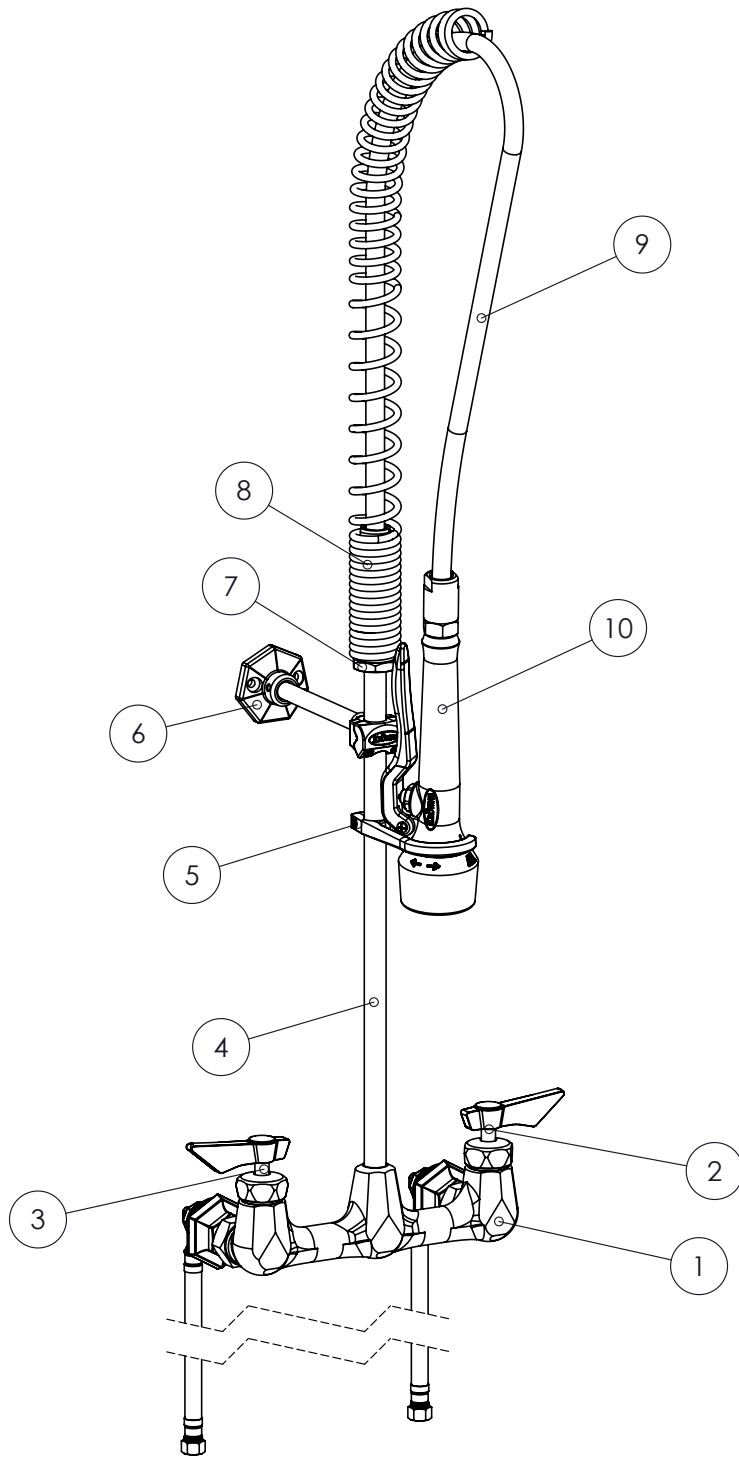

REPLACEMENT PARTS

Model	Description
1 DX-208	8" Center Wall Mount Pre-Rinse Base
1 DX-100	Coupling Flanges
2 DX-708	Cold 1/4 Turn Ceramic Cartridge Valve
3 DX-709	Hot 1/4 Turn Ceramic Cartridge Valve
4 DX-160	18" Riser Pipe
4 DX-160-24	24" Riser Pipe (Optional)
5 DX-165	Hook/Screw Assembly
6 DX-137	Wall Bracket
7 DX-161	Spring Retainer
8 DX-162	24" Spring
9 DX-133	44" Pre-Rinse Hose
10 DX-129	Spray Head (1.15 GPM)

SPRAY HEAD REPAIR PARTS

Model	Description
DX-166	Repair Kit for Spray Head (1.15 Shower Pattern)
DX-171	Spray Head Handle
DX-179	Repair Kit for Spray Head (1.15 Knife Pattern)
DX-322	Button Valve