

# LEGIOMIX® Electronic mixing valve

## 6000 series



### Function

The electronic mixing valve is used in centralized systems that produce and distribute domestic hot water. It maintains the temperature of the domestic hot water delivered to the user when there are variations in the temperature and pressure of the hot and cold water at the inlet or in the draw-off flow rate. The LEGIOMIX® electronic mixing valve provides precise temperature control over very low and very high flow rate demand, minimal pressure drop with a ball valve control element, automatic self-cleaning to prevent scale formation and easy-to-use digital interface with data logging, alarming and status indication. The LEGIOMIX® electronic mixing valve is furnished with a controller with LCD user interface that provides a set of programs for circuit thermal disinfection to kill Legionella. The controller is configurable via keypad, or local or remote computer. Depending on the type of system and habits of the user, temperature levels and operation times can be programmed as desired. In addition, it comes standard with monitoring and remote control connections.

The LEGIOMIX® 6000 series electronic mixing valves meet the requirements of ANSI/NSF 372-2011 and are certified to ASSE 1017, CSA B15.3, UPC, IPC, Low Lead Laws and listed by ICC-ES for use in accordance with the U.S. and Canadian plumbing codes.

### Product Range

- Code 6000 series Electronic mixing valve (ASSE 1017) with programmable thermal disinfection.....sizes 1", 1-1/4", 1-1/2", 2" male NPT union connections
- Code 6000 series Electronic mixing valve (ASSE 1017) with programmable thermal disinfection.....sizes 1", 1-1/4", 1-1/2", 2" sweat union connections
- Code NA10520 Modbus-to-BACnet gateway

### Technical specification

#### Valve body

- Materials:
  - Body: DZR low-lead brass
  - Ball: low-lead brass, chrome-plated
  - Hydraulic seals: peroxide-cured EPDM

- Max. body pressure rating (static): 230 psi (16 bar)
- Max. operating pressure: 150 psi (10 bar)
- Max. inlet temperature: 212°F (100°C)
- Temperature gauge scale: 30 - 210°F
- Suitable fluids: water
- Max. water hardness: 10 grains

Main connections: -NPT male and sweat union 1", 1¼", 1½" and 2"

#### Actuator, 3-wire floating fail-in-place

- Electric supply: 24 VAC - 50/60 Hz
- Power consumption: 6 VA
- Protection cover: self-extinguishing VO
- Protection class: IP 65 (NEMA 4/4X)
- Ambient temperature range: 14 - 130°F (-10 - 55°C)
- Electric supply cable length: 31½" (0.8 m)

#### Controller, LCD user interface/display

- Materials:
  - Housing: self-extinguishing ABS, color white RAL 1467
  - Cover: self-extinguishing SAN, smoked transparent
- Electric supply: 24 VAC - 50/60 Hz
- Power consumption: 6.5 VA
- Adjustment temperature range: 70 - 185°F (20 - 85°C)
- Disinfection temperature range: 100 - 185°F (40 - 85°C)
- Ambient temperature range: 32 - 120°F (0 - 50°C)
- Protection class: IP 54 (wall mounting)  
(Class II appliance)
- Mounting bracket: DIN rail

- Contact rating (R1, R3, R4): 5 A resistance, 2 A inductance / 24 V
- Mixing valve control: 5 A resistance, 2 A inductance / 24 V
- Alarm relay (R2): 5 A resistance, 2 A inductance / 24 V

- Fuses: 1 (main): 80 mA
- Fuses: 2 (mixing valve): 1 A
- Charge reserve: 15 days in the event of electric supply failure, with a 3 cell rechargeable 3.6 V 140 mAh buffer battery
- Battery recharging time: 72 hours
- Approvals: CE, FCC part 15

#### Temperature sensors

- Body material: stainless steel
- Type of sensitive element: NTC
- Working temperature range: 14 - 260°F (-10 - 125°C)
- Resistance: 10,000 Ohms at 77° F (25° C)
- Time constant: 2.5
- Max. distance for mixed outlet or return (recirculation) sensor: 500 ft (150 m) cable 2 conductor x AWG 18  
800 ft (250 m) cable 2 conductor x AWG 14

#### Mixing valve performance

- Accuracy: ± 3° F (± 2° C)
- Max. operating differential pressure (dynamic): 20 psid (1.4 bar)
- Max. ratio between inlet pressures (H/C or C/H): 2.1

#### Certifications

- ASSE 1017/CSA B125.3, certified by ICC-ES, file PMG-1357.
- NSF/ANSI 372-2011, Drinking Water System Components-Lead Content Reduction of Lead in Drinking Water Act, California Health and Safety Code 116875 S.3874, Reduction of Lead in Drinking Water Act, certified by ICC-ES, file PMG-1360.

## Dimensions

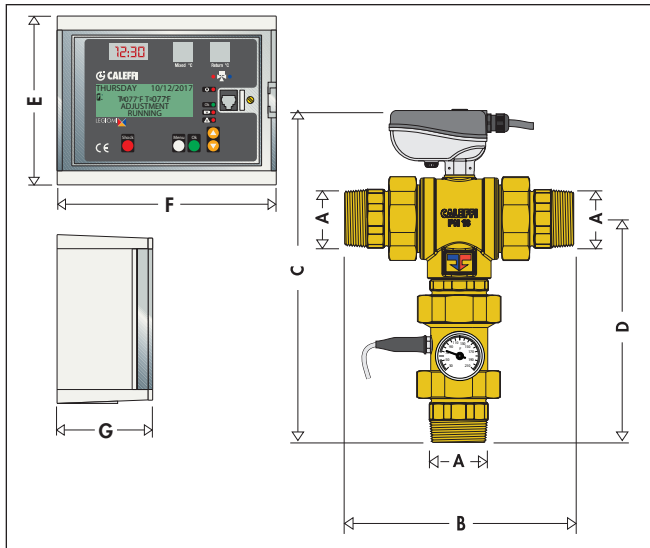

Code	A	B	C	D	E	F	G	Wt (lb)
600064A	1" MNPT	6¼"	11"	6"	5½"	7"	4"	7.3
600069A	1" sweat	4¾"	10¼"	5¼"	5½"	7"	4"	7.3
600074A	1¼" MNPT	7¼"	11 <sup>7</sup> / <sub>8</sub> "	6¼"	5½"	7"	4"	8.2
600079A	1¼" sweat	5¾"	11 <sup>1</sup> / <sub>8</sub> "	5½"	5½"	7"	4"	8.2
600084A	1½" MNPT	9 <sup>1</sup> / <sub>8</sub> "	14 <sup>3</sup> / <sub>8</sub> "	9½"	5½"	7"	4"	21.0
600089A	1½" sweat	7 <sup>7</sup> / <sub>8</sub> "	13 <sup>1</sup> / <sub>8</sub> "	8¼"	5½"	7"	4"	21.0
600094A	2" MNPT	9½"	14½"	7 <sup>5</sup> / <sub>16</sub> "	5½"	7"	4"	21.5
600099A	2" sweat	8"	13 <sup>11</sup> / <sub>16</sub> "	6½"	5½"	7"	4"	21.5

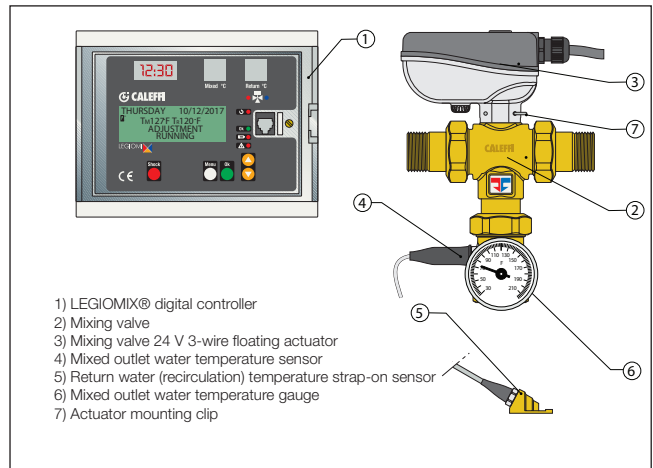

## Package contents

- Digital controller, consisting of housing and base for electric connection
- DIN bar and mounting wall anchors
- Mixing valve
- Actuator
- Mixed outlet water temperature sensor
- Return water temperature strap-on sensor
- Spare fuses
- Installation and commissioning manual

## “Legionella” - Scalding risk

In systems producing domestic hot water with storage, in order to avoid the dangerous bacteria known as "Legionella", the hot water must be stored at a temperature of at least 140°F. At this temperature it is certain that the growth of the bacteria causing this infection will be totally eliminated. However, at this temperature the water cannot be used directly, as it may cause scalding. For example, at 130°F, partial burning takes place in 30 seconds and at 140°F total burning takes place in 5 seconds.

In view of the above, it is necessary to install an electronic mixing valve which can:

- reduce the temperature at the point of use to a value lower than that of storage;
- maintain this value when the incoming pressure and temperature conditions vary.

## Thermal disinfection

The diagram to the right shows the behavior of the bacteria "Legionella Pneumophila" when the temperature conditions of the water in which it is contained vary, in laboratory sample population. In order to ensure proper thermal "disinfection", the value must not be below 140°F.

## Reference documents

For the prevention and control of Legionella, see the ASHRAE Standard 12-2000 and 188-2015.

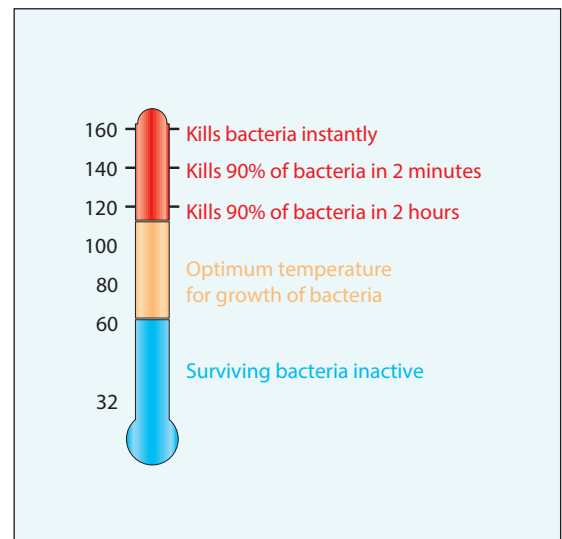

## Operating principle

The electronic mixing valve mixes hot water from storage and cold water from the main supply to maintain a constant controlled set temperature of mixed water at the outlet. The controller measures the temperature of the mixed water at the valve outlet with temperature sensor and modulates the mixing valve position to maintain the desired set temperature. Despite variations in pressure drop or hot and cold water usage or variations in inlet temperature, the LEGIOMIX® automatically controls the water temperature to meet the temperature setting.

A built-in clock is used to enable optional disinfection cycle programs. The system is disinfected by raising the water temperature to a specific value for a specific time duration. Using the recirculation temperature sensor, water returning from the distribution circuits can be measured for thermal distribution control. This measured temperature is used to check and control the temperature reached over all or part of the distribution network with this sensor placed at the end of the recirculation piping circuit.

The LEGIOMIX® can be used to confirm that the correct temperature and time for thermal disinfection have been reached before taking the appropriate corrective action. All the parameters are updated every day and logged, with temperatures recorded every hour. There is an RS-485 connection for remote monitoring and configuration and, with specific relays, makes alarm signals and controls available to other interconnected system devices. A Modbus-to-BACnet gateway and inlet port check valves are available separately.

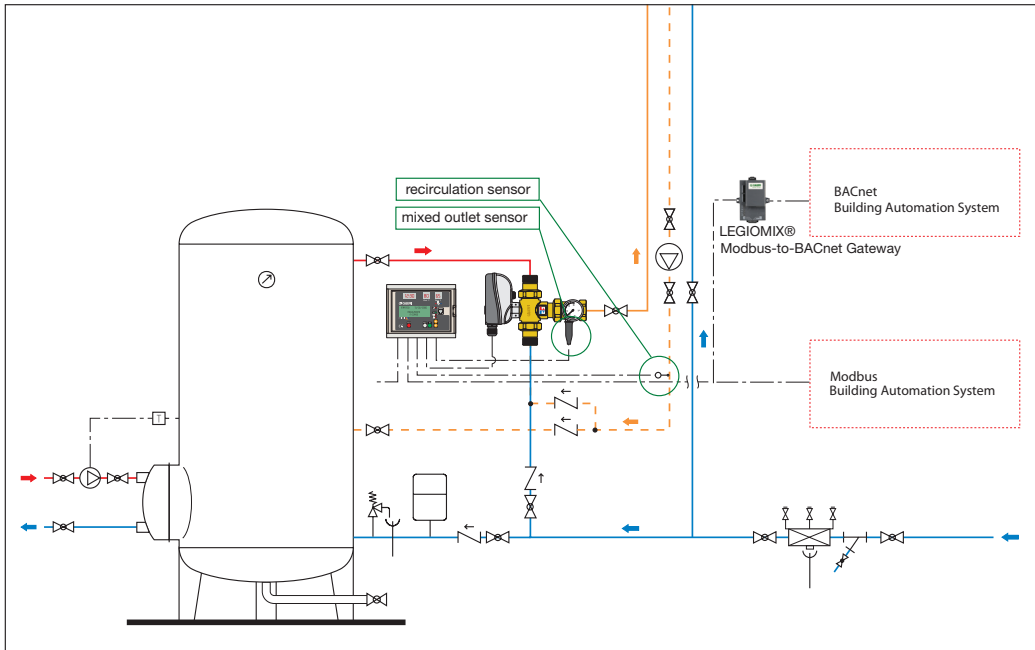
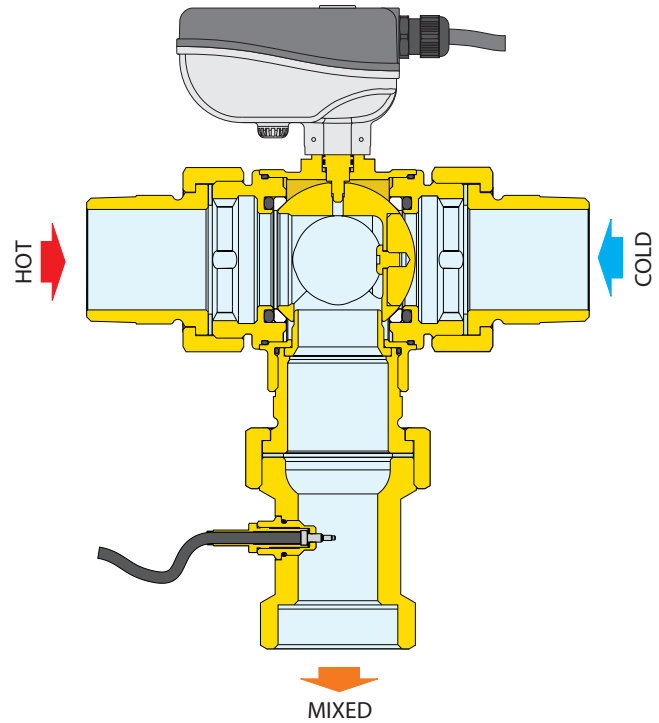

## Modbus-to-BACnet gateway for remote control

The LEGIOMIX® Modbus-to-BACnet gateway, code NA10520, allows the transfer of data to a Building Automation System using BACnet communication protocol.

### Hydraulic Characteristics

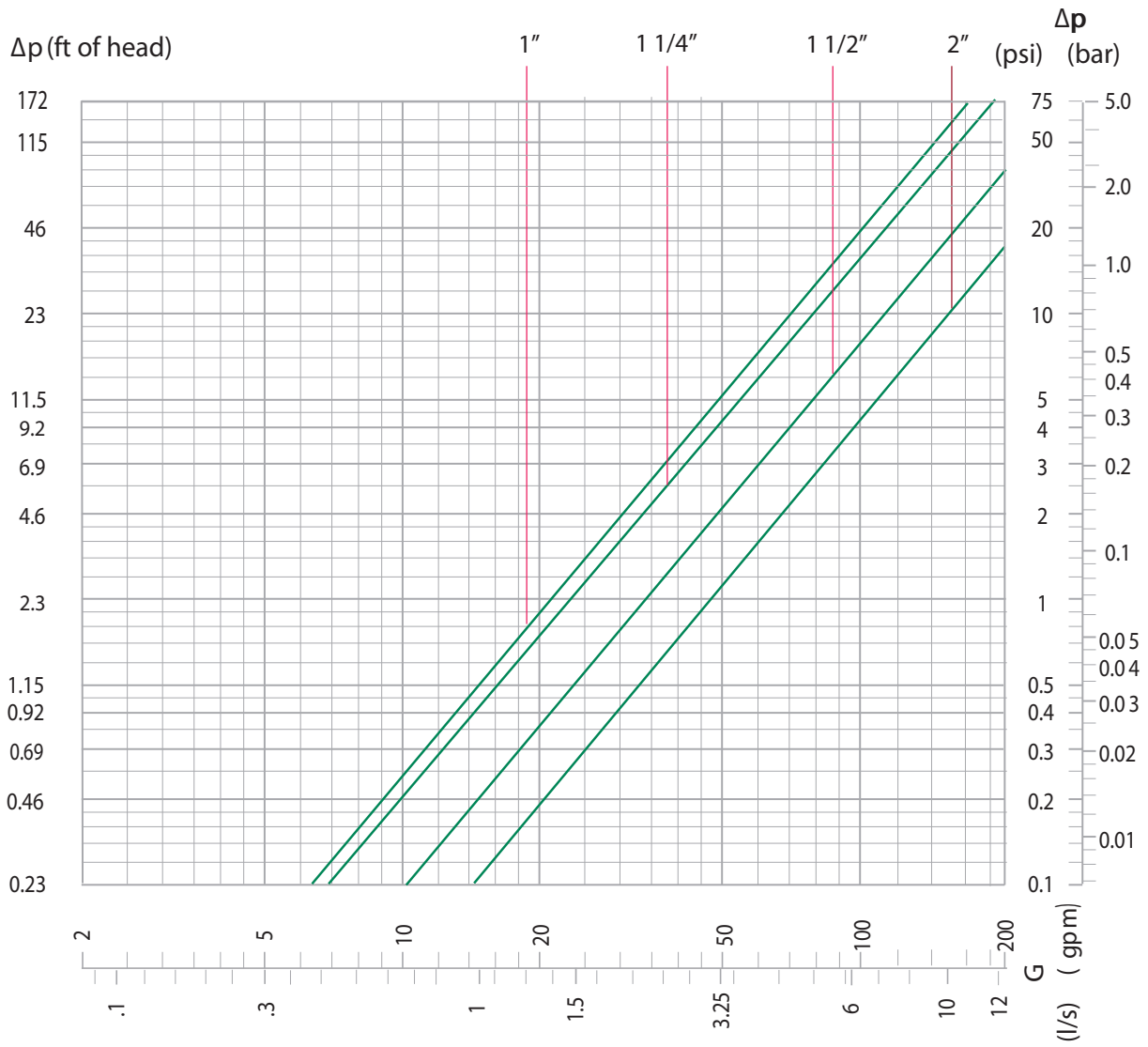

Size	Pressure drop (psi)			
	5	10	15	20*
<b>GPM (using type M copper pipe)</b>				
1"	47	66	81	94
1 1/4"	54	76	93	107
1 1/2"	76	108	132	152
2"	107	152	186	215

\*Maximum recommended differential pressure is 20 psid to ensure stable operation and accurate temperature control.

Size	Recommended Flow Rates (gpm/lpm)			
	1"	1 1/4"	1 1/2"	2"
Minimum*	3.1 / 11.7	4.4 / 16.6	6.6 / 25	8.8 / 33.3
Maximum	94 / 356	107 / 405	152 / 575	215 / 814
Cv	21	24	34	47

\*to ensure stable operation and accurate temperature control.  
Minimum flow rate is 0 gpm when recirculation flow rate is greater than or equal to the valve size minimum flow rating.

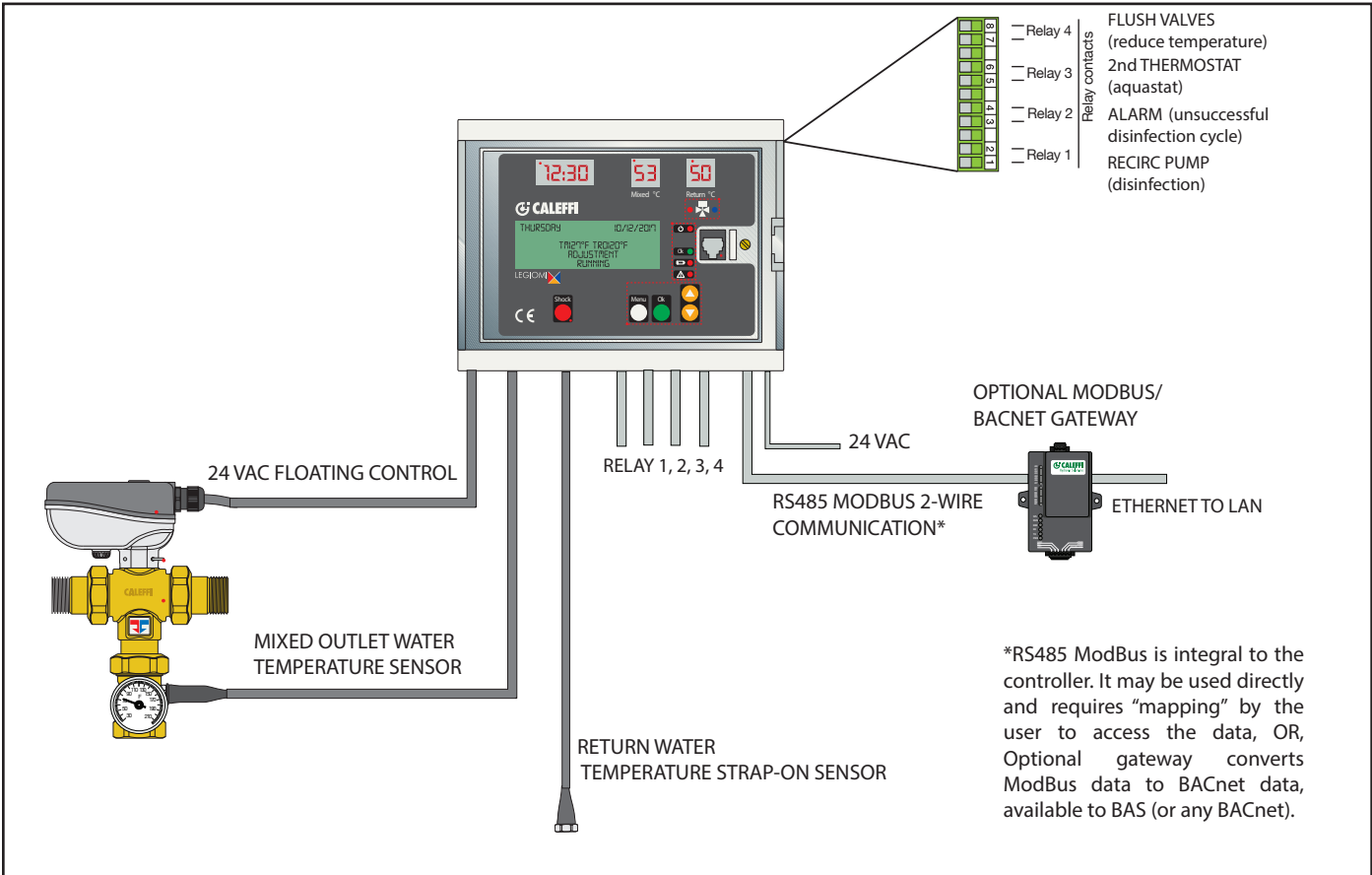

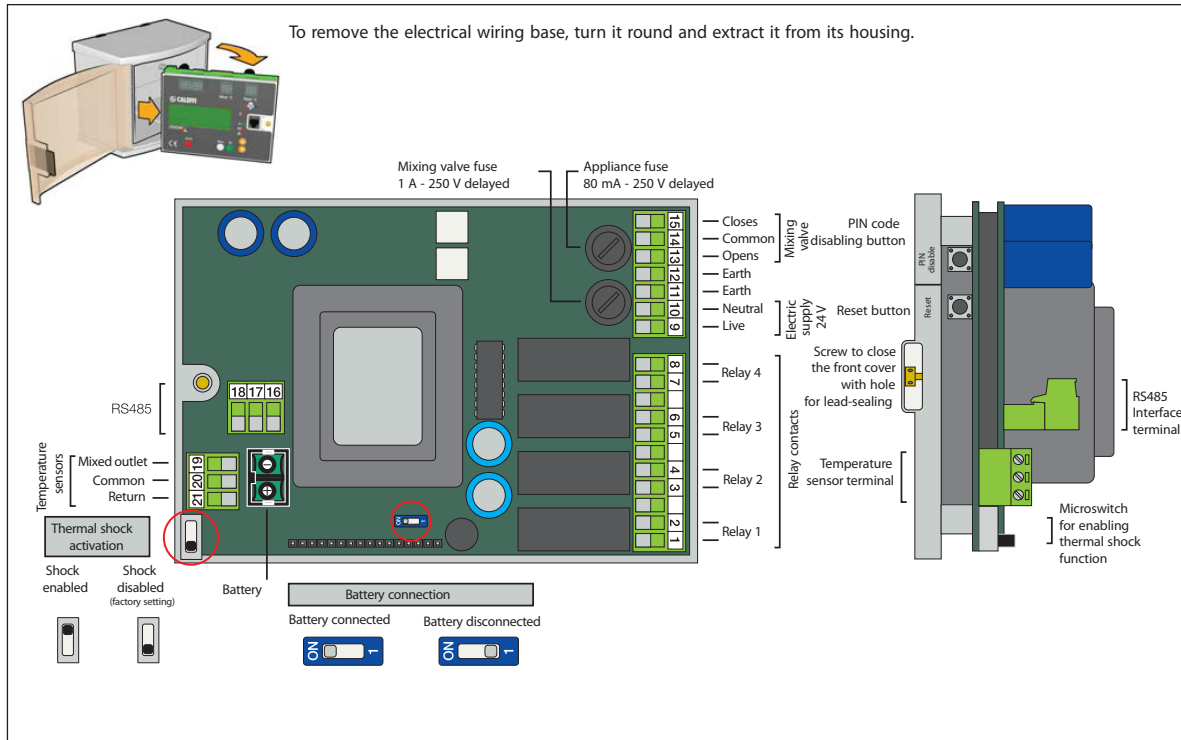

**Back panel**

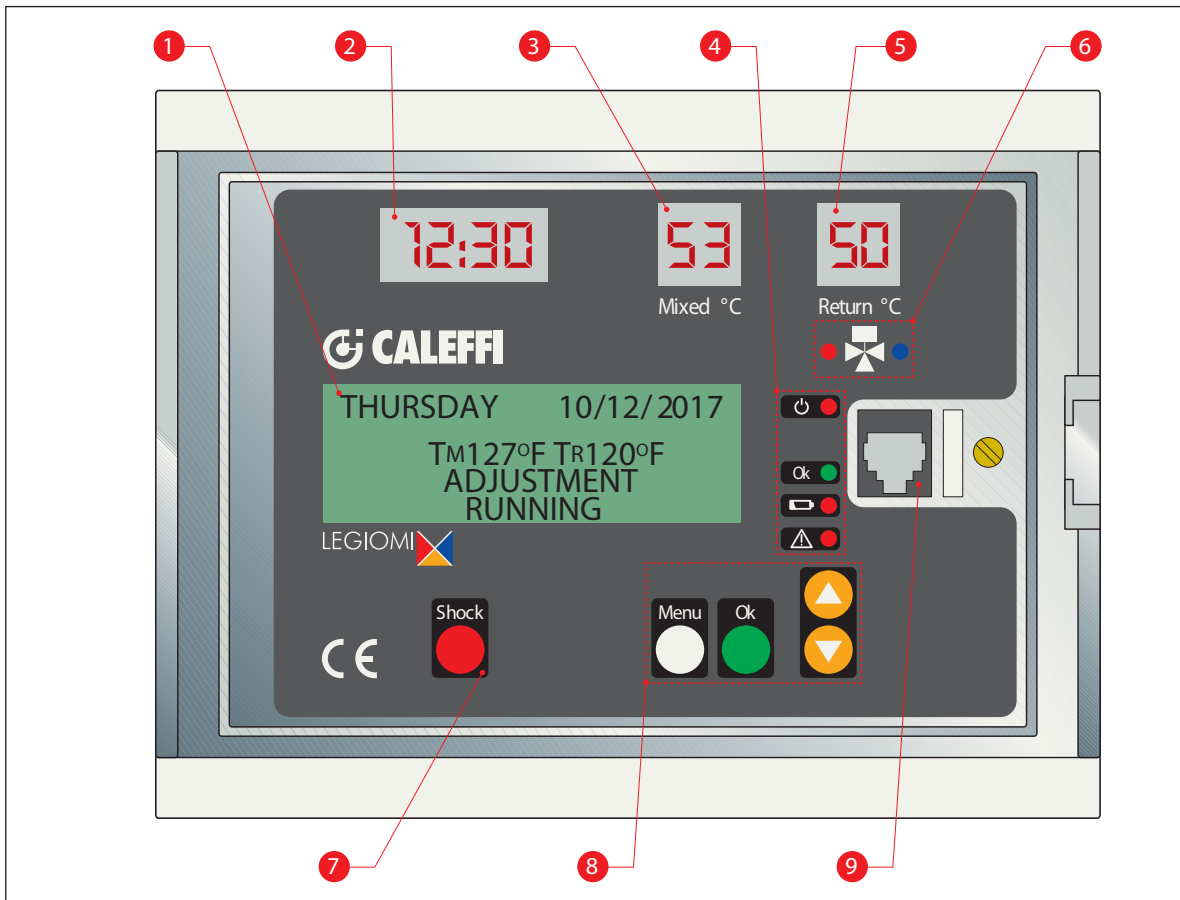

Front panel



- 1. LCD display\*
- 2. LED display: Time
- 3. LED display: Tmixed- Mixed Outlet water temperature (°C only)\*\*
- 4. LED indicator
- ON
- Status OK
- Battery
- Alarm

- 5. LED display: Treturn - return water (recirculation) temperature (°C only)\*\*
- 6. Mixing valve open/close LED
- 7. Thermal shock button
- 8. Navigation buttons
- Menu
- OK
-  UP
-  DOWN

- 9. RS 485 front connection

\*Tmixed and Treturn is displayed, default °F. Can be changed to °C in settings (Cels.-Fahr.)  
 \*\*Can be turned off in settings (LED Display).

## Indication description

### Indications on LED display

3 LED displays on the front of the controller show the clock time and temperature of the mixed outlet water temperature and return temperature sensors at all times.

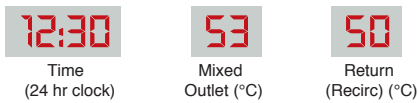

The default setting for the temperatures is OFF. Go to SETTINGS, LED DISPLAY to turn them on. Also, if the recirculation sensor has been set as "not present" in SETTINGS, or is faulty in program 0, the related display remains OFF. Temperatures are in °C only, and can not be changed to °F.

	Hour and minutes display (24 hour system)
	Sensor temperature display (in °C) Resolution 1 °C
	Sensor warning display "out of range" at top. (blinking)
	Sensor warning display "out of range" at bottom. (blinking)
	Sensor warning display "open". (blinking)
	Sensor warning display "short circuit". (blinking)

### LED indicators

The following LED indicators are located on the front of the controller:



## Disinfection

LEGIOMIX® runs the disinfection phase, which consists of raising the water temperature to a pre-set value for a specific time duration, by operating the mixing valve as required.

Using the menu, set the days of the week for the disinfection phase to run.

At the end of disinfection, statistical data relating to the just concluded disinfection are logged.

This mode begins and ends automatically at a start time (Time ON) and end time (Time OFF) that can be selected by the user in SETTINGS.

**Safety measures must be in place before engaging disinfection mode. Anti-scald protection devices, certified to ASSE 1016 or ASSE 1070, at all downstream fixtures, must be installed.**

## CONFIRMING DISINFECTION

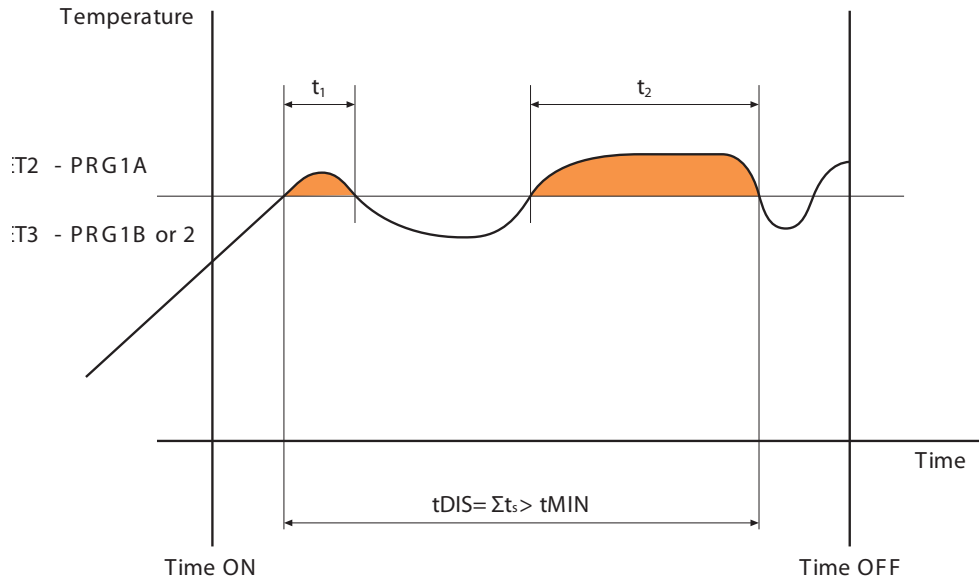

NOTE: Graph is for reference only, not shown on display or logged data.

If, within the time span (Time OFF - Time ON), the actual disinfection time reaches  $t_{DIS}$  is greater than the set  $t_{MIN}$ , the disinfection is concluded with a positive outcome. It automatically exits this status and returns to the adjustment (modulating) mode.

If the sufficient time  $t_{DIS}$  is not reached, the disinfection phase ends at Time OFF.



## **Programs**

The operation of the controller during disinfection can be set according to different programs, selected depending on the type of system and management of the system. Set the program, and the day and time to turn on and turn off disinfection, in parameters in SETTINGS.

### **Program 0**

Features continuous mixed outlet water temperature modulation with automatic disinfection in a time band that can be set. Disinfection will run only when the Program Day (ProgDay) parameter has days selected (default is no days) and the TimeOn and TimeOff parameters are filled in (default is 00:00 for both). The return water temperature sensor is not used, but if present, it is used as a monitor only. During the disinfection phase, the mixed outlet water temperature must remain above SET2 for a time tDIS at least equal to tMIN, and if this occurs then disinfection has been successful. When this happens, disinfection then stops. If disinfection is not successful, there is no alarm signal. If alarm indication for unsuccessful disinfection is desired, use other programs.

### **Program 1A**

Features continuous mixed outlet water temperature modulation with automatic disinfection in a time band that can be set. Disinfection will run only when the Program Day (ProgDay) parameter has days selected (default is no days) and the TimeOn and TimeOff parameters are filled in (default is 00:00 for both). The return water temperature sensor is not used, but if present, it is used as a monitor only. During the disinfection phase, the mixed outlet water temperature must remain above SET2 for a time tDIS at least equal to tMIN, and if this occurs then disinfection has been successful. When this happens, disinfection then stops. If the disinfection temperature is not reached or it cannot be maintained for a sufficient period of time, the alarm for unsuccessful disinfection is generated. The alarm is recorded in the log. The first time a button is pressed, the relay opens again. The other alarm indications are cleared at the next successful disinfection.

### **Program 1B**

This program can only be set if the return water temperature sensor is set at present. Identical to the previous program (1A), the only difference is the successful outcome of the disinfection phase is checked via the return water temperature sensor in relation to SET3 instead of via the mixed outlet water temperature sensor in relation to SET2. As soon as conditions indicate successful disinfection, disinfection then stops. If the disinfection temperature is not reached or it cannot be maintained for a sufficient period of time, the alarm for unsuccessful disinfection is generated. The alarm is recorded in the log. The first time a button is pressed, the relay opens again. The other alarm indications are cleared at the next successful disinfection.

### **Program 2 (factory settings - default)**

This program can only be set if the return water temperature sensor is used. By default, the disinfection is not enabled (no days are selected). If days are selected during commissioning, it is identical to the previous program (1B). The only difference is, if the return water temperature does not reach SET3 after a wait period (tWAIT) since the start of disinfection, the mixed outlet water temperature SET2 is increased by a value equal to (SET3 - TR reached), considering that SET2 can not in any case exceed the limit of SETMAX. This correction procedure (increasing only) of the disinfection SET is iterative: if necessary, it is repeated in the time span defined by the TimeOn and TimeOff at each time interval equal to tWAIT. As soon as conditions indicate successful disinfection, disinfection then stops. If the disinfection temperature is not reached or it cannot be maintained for a sufficient period of time, the alarm for unsuccessful disinfection is generated. The alarm is recorded in the log. The first time a button is pressed, the relay opens again. The other alarm indications are cleared at the next successful disinfection.

## Thermal disinfection

The temperatures and corresponding disinfection times for the network must be chosen according to the type of system and the related intended use. The following criteria is generally followed, guided by....

T = 160° F (70° C) for 10 minutes

T = 150° F (65° C) for 15 minutes

T = 140° F (60° C) for 30 minutes

Thermal disinfection is generally performed during times of reduced system usage, ie: nighttime. This minimizes the potential for scald conditions to occur. Thermal disinfection is recommended to be run every day and at least once per week.

**Safety measures must be in place before engaging disinfection mode. Anti-scald protection devices, certified to ASSE 1016 or ASSE 1070, at all downstream fixtures, must be installed.**

## Interrupting disinfection

**Disinfection can be interrupted while it is still in progress.** On the working screen (showing the message “disinfection in progress”), press the OK button once. The display shows the message “Cancel disinfection?”; and at this point, the OK button can be pressed to stop the disinfection phase and return to the adjustment function (without going through the flush phase). If the OK button is not pressed, after a timeout of about 3 seconds, the display goes back to displaying the message “disinfection running”.

**Table of thermal disinfection programs**

Program # >	0	1A	1B	1B	2
<b>type of confirmation</b>	Adjustment and simple disinfection without confirming	Adjustment and disinfection confirming on the mixed outlet water temperature	Adjustment and disinfection check on return temperature to the central heating system	Continuous disinfection (max. 4 hours)	Adjustment only (default). If scheduled, disinfection confirming.
<b>Use of return sensor</b>	NO	NO	YES	YES	YES
<b>Return sensor shown on LED display</b>	As monitor only	As monitor only	YES	YES	YES
<b>Adjustment temperature</b>	Flow*: (SET1) 68 - 185° F	Flow*: (SET1) 68 - 185° F	Flow*: (SET1) 68 - 185° F	--	Flow*: (SET1) 68 - 185° F
<b>Disinfection temperature</b>	Flow*: (SET2) 104 - 185° F	Flow*: (SET2) 104 - 185° F	Recirculation: (SET3) 104 - 185° F	Recirculation: (SET3) 104 - 185° F - 24 hours	Recirculation: (SET3) 104 - 185° F - with adjustment of flow* up to the max value
<b>Alarm if disinfection unsuccessful</b>	NONE	YES	YES	YES	YES
<b>Recording in log if disinfection unsuccessful</b>	NONE	YES	YES	YES	YES

\*mixed outlet water temperature

## Flushing

LEGIOMIX® automatically enters this mode at the end of the disinfection phase, and is used to make the water temperature return to the adjustment value (SET1 value) quicker, or to periodically clear (or flush) the storage of impurities. This phase is ended after a time selected with the tFLUX parameter. When flushing time has ended, relay 1, relay 4, and the controller returns to the “adjustment” mode.

## Thermal shock

LEGIOMIX® adjusts the mixed outlet water temperature at the set shock value (SETSH) for a selected time duration (tSH). The Shock button on the front of the controller can be used then to initiate thermal disinfection, the manual mode. This function is associated with activation of alarm 4 (AL4), and illumination of the alarm LED. Thermal shock can be started by pressing the specific button on the front panel (press and hold for at least 5 seconds) while the operating screen is displayed, or to program it with the menu item for a delayed execution (countdown in minutes), or by remote control.

**Thermal shock operation can be stopped, if needed, by pressing the shock button and confirming with the “OK” button, or by remote control.**

This is a potentially dangerous function so a jumper is provided on the printed circuit board to enable it. If the jumper is closed, the Shock function can be used; if it is open, it is not available (see Back Panel section).

At the end of the Thermal shock phase, the controller reverts to the “adjustment” (modulating) mode.

## Low power

LEGIOMIX® goes into low power mode with loss of power, and continues to run the internal date clock. NOTE: in this condition there is no power for switching relays, so the controller does not perform the adjustment or disinfection functions, sensor temperatures can not be acquired, and no communication functionality is available. The mixing valve remains in the last state when power went out. LCD and LED displays are off, all LEDs are off, except the “alarm” LED, which will be flashing.

When the power comes back on, the blackout is recorded in the log (alarm AL5) and the controller returns to operating mode as programmed, unless the power failure lasts long enough to completely run down the battery. In this case, LEGIOMIX® will be reset to default values when the power is restored.

In the event of a reset or extended power failure, factory settings are restored. If modifying the factory settings, make a copy of the new settings.

## ANTI-CLOG function

The LEGIOMIX® controller is configured to execute a daily ball rotation cycle, to ensure efficient ball operation and cleaning. This occurs after the disinfection program concludes, if active, or in any case after 24 hours has elapsed when disinfection is not active. The ANTI-CLOG function can be deactivated through the ANTI-CLOG step in the “SETTINGS” menu by entering the release code 5566 and confirming with ON-OFF. Eliminating this function increases the risk of deposits forming on the moving parts of the valve.

If it is necessary to also eliminate the disinfection function, proceed in the following order: 1. eliminate the ANTI-CLOG function, then 2. eliminate the disinfection function.

## Reset

On the back panel, there is a specific reset button, in case it is necessary to restore the initial settings.

**If the date and time are not set after the reset, the controller will operate according to the factory default settings.**

## Actuation relays

The circuit board and terminals show the relay contacts used to manage auxiliary equipment and to report alarms.

- Relay 1: Circulation pump (**active during disinfection**) connect Relay 1 in parallel to time clock or aquastat contacts (whatever switch is controlling recirculation pump).
- Relay 2: Generic alarm (sensor fault, battery fault, blackout or clock failure).
- Relay 3: Second thermostat. Wire in parallel to high temperature thermostat. Use to increase hot water supply temperature for thermal disinfection.
- Relay 4: Flushing valves

## Summary of actuation relay status

Operating Status	Adjustment	Disinfection	Flushing	Thermal shock
Relay	Contact status	Contact status	Contact status	Contact status
Relay 1: recirc pump	Open	Closed	Closed	Closed
Relay 2: generic alarm	Open	Open	Open	Closed
Relay 3: second thermostat	Open	Closed	Open	Closed
Relay 4: flush valves	Open	Open	Closed	Open

## Relay contact for recirculation pump and second storage thermostat

Wiring diagram of relay 1 with a clock for managing the recirculation pump times.

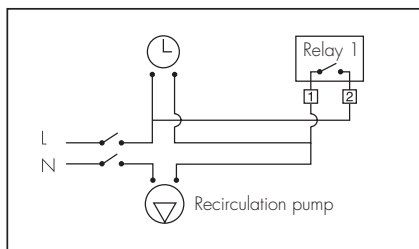

Wiring diagram of relay 3 for connecting the second thermostat on hot water storage.

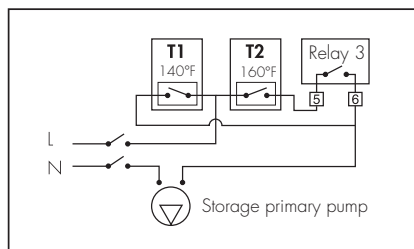

## Alarm management

To make it easier to resolve any functional faults that occur after installation and commissioning, the controller is configured so that faults are indicated by special alarms and the appropriate action is taken. The cause of the alarm is shown on the LCD display. If the alarm does not inhibit all the functions, the alarm screen will alternate with controller status screen.

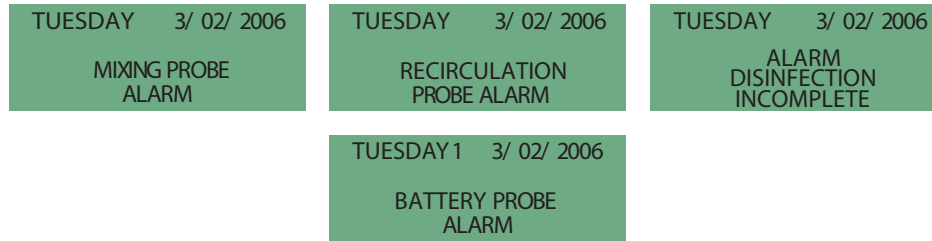

## Alarm description

Alarm indicator	Description
AL1	Mixed outlet water temperature sensor fault
AL2	Return water temperature sensor fault
AL3	Disinfection failed
AL4	Thermal shock in progress
AL5	Main power failure
AL6	Controller reset
AL7	Battery default

Depending on the alarm type, certain actions occur, relay statuses modified and information shown on the LED display, LCD display and LEDs on the front panel.

## Log

The "log" is a FIFO (First In - First Out) loop buffer that is continually updated and records parameters relating to adjustment and disinfection phases that occurred during the day. Data is stored for the last 40 days, after which the data for the first day is overwritten, etc. The hourly average mixed outlet and return water temperatures are saved to Eeprom every hour, and alarms are saved at the time they occur. The average hourly values of the current day can be viewed at any time. The disinfection data is saved when disinfection ends. The log (via specific menu item) can be viewed on the display or remotely via the RS485 serial interface.

The parameters saved in the log are:

-Date (day, month, year)

-Set program. This is saved when disinfection starts.

-tDIS: actual disinfection time (in steps of minutes).

When the set program is 0 or 1A, this parameter is the time when the temperature of the mixed outlet water was above SET2.

When the set program is 1B or 2, this parameter is the time when the temperature of the return water was above SET3.

This is helpful when it is less than tMIN, to understand how much greater the span of TIME ON: TIME OFF should be to complete the disinfection.

-TRMAX: Max. temperature of the return water sensor during disinfection (if a disinfection was completed that day).

-TRMIN: Min. temperature of the return water sensor during disinfection (if a disinfection was completed that day). It is calculated from the time when the return water sensor measured a value greater than SET3, beginning from the time when the disinfection starts being effective.

-ALARMS AL1, AL2, AL3, AL4, AL5, AL6, AL7 if they were activated on the day in question.

-24 hourly average values of the mixed outlet water temperature.

-24 hourly average values of the return water temperature.

If no disinfection was completed on that day, then the related fields will contain a default value.

If there have been any faults in one or both sensors, the hourly average data will be represented by dashes. If there are any gaps or unavailable data due to a change of date, time, etc., the cells will contain a default value and will be represented on the display by dashes.

HISTORIC 06/ 04/ 2005 t DIS 060' PGRM 1A TR MAX 130° TR MIN 120° ALARM --4-5-7-	HISTORIC 06/ 04/ 2005 H 01 02 03 04 05 06 TA --- --- --- --- --- --- TR --- --- --- --- --- ---	HISTORIC 06/ 04/ 2005 H 07 08 09 10 11 12 TA 120 120 120 122 119 123 TR 116 116 116 116 118 117
--	--	--

## Remote control

The controller can be controlled from a remote computer with the RS485 serial output connection, which can be accessed by hard-wired terminals and through the connector on the front panel. Since the interface is the multipoint bus type it is necessary for each controller connected on the bus to be identified by an appropriate address to avoid identification conflicts. For a detailed description of the operations and controls that are available from a remote location using this interface, refer to the relevant documentation.

Contact Caleffi for list of registers (points) for mapping LEGIOMIX® information to ModBus. Configuration, mapping, hardware (routers, modem, etc.), and software are customer/user responsibility. Code NA10520 Modbus-to-BACnet gateway is available separately for translating ModBus to BACnet.

## Plumbing installation

Before installing the LEGIOMIX® electronic mixing valve, pipes must be flushed to prevent impurities in the water from affecting performance. Always install strainers of appropriately sized capacity at the inlet from the water main supply. Caleffi LEGIOMIX® electronic mixing valves must be installed as shown below, conforming to applicable codes, and installed either vertically or horizontally, but the actuator must never be oriented upside down.

The mixing valve body indicates with arrows, hot water inlet- red, cold water inlet - blue.

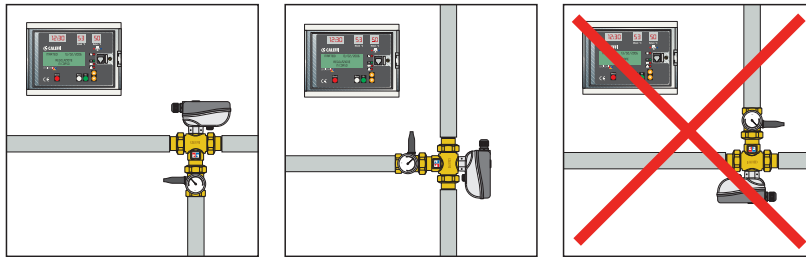

## Check valve

In systems with mixing valves, check valves should be installed to prevent backflows, as is shown in the application diagrams. Check valves, code NA10366 (for 1" and 1¼" LEGIOMIX®) and NA10367 (for 1½" and 2" LEGIOMIX®) may be used.

## Commissioning

Due to the special purpose for electronic mixing valves, commissioning in accordance with current regulations and by qualified personnel using suitable instruments is required. Check that the hot and cold water supply pressures are within operating limits of the mixing valve, see technical specifications. Check the temperature of the hot water coming from storage, greater than or equal to 140°F (60°C). Record all parameters settings and measurements taken in the installation log book.

## Maintenance

During service, regularly monitor the performance of the LEGIOMIX® electronic mixing valve since any loss of performance may indicate maintenance is needed for the valve or the system. If the temperature of the mixed water is found to have changed significantly compared to previous recordings, refer to installation and commissioning sections. The following check points are recommended periodically, at least every 12 months or more frequently, to ensure that the valve continues to deliver optimum levels of performance:

- 1) Check and clean the filters installed in the system.
- 2) Check that any check valve installed at the inlet of the LEGIOMIX® electronic mixing valve is functioning correctly, and there are no leaks caused by dirt.
- 3) The internal components of the valve can be descaled by immersing in a suitable descaling fluid.
- 4) Follow commissioning procedure again after maintainable components have been checked.
- 5) Record all operations conducted on system log book.



Modbus-to-BACnet gateway.  
Converts LEGIOMIX® controller Modbus (RS-485 serial) output communication to BACnet IP (Ethernet) communication.



Inlet check valve assembly for installing on inlet union tail pieces of LEGIOMIX® mixing valves, if required. Stainless steel body (no lead), acetal plastic check valve insert with NBR o-ring. Order separately, field installed. 2 required per valve.

Code	Description	Lbs
NA10520	Modbus-to-BACnet gateway	1.2

Code	Description	Open Pressure	Lbs
NA10366	Check valve assembly 1" & 1¼"	0.23 psi	1.0
NA10367	Check valve assembly 1½" & 2"	0.20 psi	1.5

### Application diagrams

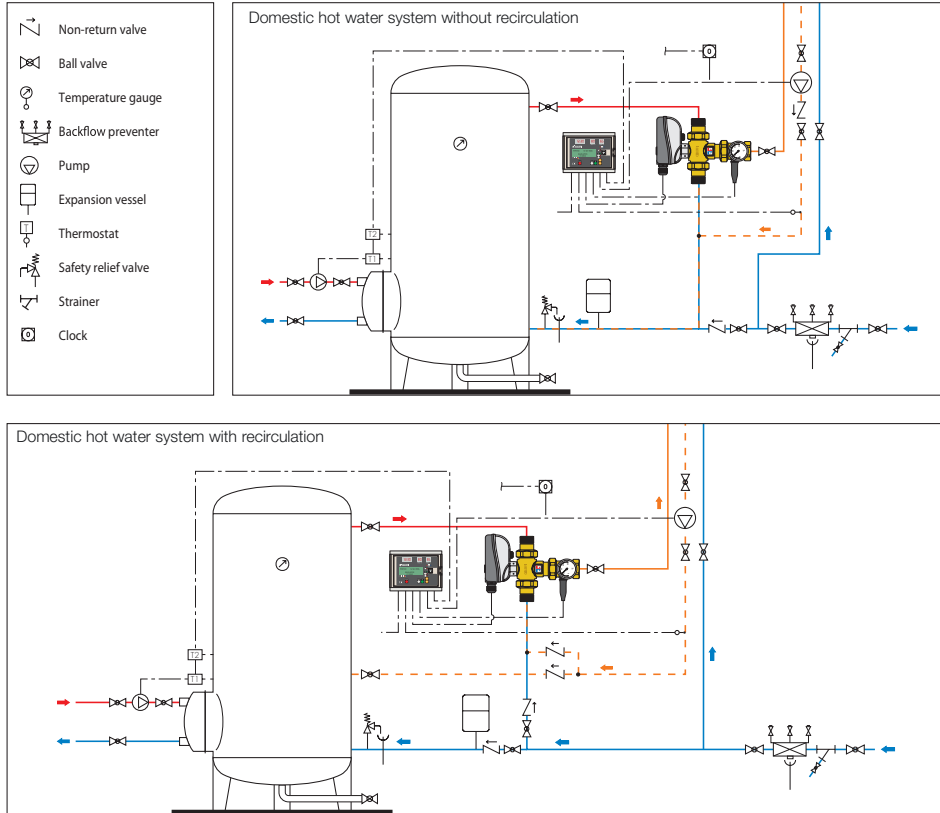

# NOTES

THE LEGIOMIX® 6000 SERIES POINT-OF-DISTRIBUTION (ASSE 1017) ELECTRONIC MIXING VALVE IS INTENDED TO BE BUT ONE COMPONENT IN AN OVERALL RISK MANAGEMENT PLAN AS DESCRIBED IN ANSI/ASHRAE STANDARD 188 "LEGIONELLOSIS: RISK MANAGEMENT FOR BUILDING WATER SYSTEMS". WHEN INSTALLED AND USED AS DESIGNED AND INTENDED, THE LEGIOMIX® CAN HELP REDUCE BACTERIA IN DOMESTIC HOT WATER RECIRCULATION SYSTEMS, HOWEVER DUE TO SYSTEM-DEPENDENT VARIABLES, 100% ERADICATION CAN NOT BE GUARANTEED. CALEFFI IS NOT RESPONSIBLE FOR ANY DAMAGES, CONSEQUENTIAL OR OTHER, THAT MAY ARISE FROM LEGIONELLA ILLNESS WHEN USING THE LEGIOMIX® ELECTRONIC MIXING VALVE.

## SPECIFICATION SUMMARIES

### 6000 series

Electronic mixing valve. ASSE 1017/CSA B15.3 certified by ICC-ES. **Valve body:** Threaded NPT or sweat connections from 1" to 2" with unions and tailpieces. DZR low-lead brass body (<0.25% lead content), meets requirements of IPC, IRC, UPC, NPC and ANSI/NSF 372-2011 certified by ICC-ES. Low-lead brass, chrome-plated ball, and peroxide-cured EPDM hydraulic seals. Maximum body pressure rating (static) 230 psi (16 bar). Max. operating pressure 150 psi (10 bar). Max. inlet temperature 212°F (100°C). Complete with mixed outlet temperature gauge, 30°F to 210°F scale, 2 inch diameter. Flow ranges: 1 inch: Cv 21, 3.1 to 94 gpm (11.7 to 356 lpm); 1 ¼ inch: Cv 24, 4.4 to 107 gpm (16.6 to 405 lpm); 1 ½ inch: Cv 34, 6.6 to 152 gpm (25 to 575 lpm); 2 inch: Cv 47, 8.8 to 215 gpm (33.3 to 814 lpm). **Actuator:** 3-wire floating fail-in-place with intergral position indicator, electric supply 24 VAC - 50/60 Hz direct from controller. Power consumption 6 VA. Self-extinguishing VO cover, protection class IP65 (NEMA 4/4X). Ambient temperature range 14°F to 130°F (-10°C to 55°C). Supply cable length 31½" (0.8 m). **Mixing valve:** Maximum recommended operating differential pressure (dynamic) 20 psi (1.4 bar). Max. inlet pressure ratio (H/C or C/H) 2.1. Temperature stability ± 3°F (± 2°C). Maximum water hardness: 10 grains. **Controller:** Electric supply 24 VAC - 50/60 Hz. Power consumption 6.5 VA. Adjustment temperature setting range 70°F to 185°F (20°C to 85°C), Disinfection temperature range 100 to 185°F (40 to 85°C). Ambient temperature range 32°F to 120°F (0°C to 50°C). Self-extinguishing ABS, color white RAL 1467 housing, self-extinguishing SAN, smoked transparent cover, protection class IP 54 (wall mounting) Class II appliance. CE and FCC part 15 approvals. Choice of 11 languages with set of programs for selectable automatic scheduling circuit thermal disinfection to kill Legionella, configurable via keypad, or local or remote controller; with additional functions of daily ball rotation cycle to flush debris, flush valve relay output, data logging (40 day FIFO loop buffer), alarming, and status indication. Provided with two NTC element 10,000 ohm stainless steel temperature sensors for mixed outlet water temperature and return water temperature, strap-on style, for recirculation. Provide with optional stainless steel inlet port check valve assembly with a acetal plastic check valve insert and NBR o-ring, field installed, code NA10366 (1 inch and 1¼ inch), NA10367 (1½ inch and 2 inch). Provide with Modbus-to-BACnet gateway for BAS integration, code NA10520.

*We reserve the right to change our products and their relevant technical data, contained in this publication, at any time and without prior notice.*



Caleffi North America, Inc.  
3883 W. Milwaukee Road  
Milwaukee, WI 53208  
Tel: 414-238-2360 · Fax: 414-238-2366  
sales@caleffi.com · www.caleffi.com  
© Copyright 2018 Caleffi North America, Inc.