



⚠ WARNING
DISCONNECT POWER BEFORE RE-LAMPING OR WIRING THE FIXTURE
READ ALL INSTRUCTIONS COMPLETELY BEFORE STARTING INSTALLATION.

⚠ CAUTION

- TO AVOID THE RISK OF FIRE OR SHOCK, FIXTURE MUST BE INSTALLED IN COMPLIANCE WITH ALL APPLICABLE NATIONAL AND LOCAL ELECTRICAL/BUILDING CODES.
- INSTALLATION AND MAINTENANCE OF THIS UNIT REQUIRES AN ELECTRICIAN OR CERTIFIED FACTORY TRAINED TECHNICIAN.
- If an existing fixture is being replaced, remove it and note to which of the wires in the outlet box the fixture was attached. DO NOT SEPARATE ANY OTHER WIRES THAT MAY BE IN THE BOX. DO NOT DAMAGE THE INSULATION OF OLDER WIRING. In regular circumstances the BLACK wire will be the "Hot" lead and the WHITE wire will be the "Neutral" or "Common" lead A GREEN or BARE COPPER wire is the "Ground". In older buildings it is always good practice to reconfirm the polarity of the wiring.

NOTICE

- The important safeguards and instructions outlined on this sheet cannot cover all possible conditions and situations that may occur. It must be understood that common sense, caution and care factors that cannot be built into any product. Caution and care must be supplied by the person(s) installing, operating and caring of this lighting fixture.
- This fixture is designed to be mounted on a correctly installed standard round or octagon box or a through wiring box with a plaster frame. The box must be securely mounted to the structure of the building. The crossbar and hardware supplied should be used. Directly mounting the fixture to the outlet box may make it impossible to correctly align the fixture.

FIXTURE PREPARATION

1. Remove the fixture, glass/metal parts and parts bag(s) from the carton.

NOTICE:
Before discarding the carton,
double check to make certain that all parts are found.

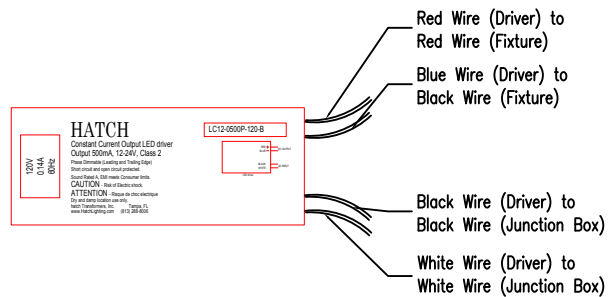

FIXTURE INSTALLATION

1. Place the led driver inside the outlet box and start wiring the fixture. Fasten black (+) wire from the junction box to LED driver black wire (+) and white wire (-) from junction box fasten to driver white wire (-). (See Fig. 1)

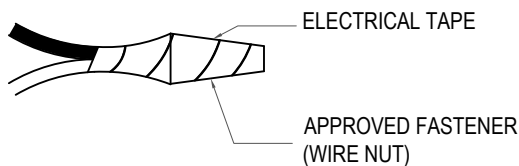

2. Attach the mounting bracket to the outlet box using the mounting screws. (See figure 2).

SEE ALSO DRIVER COLOR CODING
 LED LAMP TO LED DRIVER
 WIRE CONNECTION DETAILS

FIGURE-1



WARNING

Never fasten the ground wire to the black or "hot" wire! Failure to follow this instruction could result in serious injury or death!

4. Connect by fastening the wire black wire (-) coming from the fixture into the led driver where there as blue wire (-) indicated.



WARNING

Make sure that there is no exposed wire or strands that could cause a dangerous short circuit!

5. Connect by fastening the red wire (+) coming from the fixture into the led driver where there as red wire (+) indicated.

6. Using the two (2) flat screws, fasten the fixture to the outlet box through the side holes.

NOTICE:

Must use a incandescent dimmer with LED's on this fixture. *Lutron Maestro dimmer not compatible.

7. Restore power to circuit at breaker or fuse box.

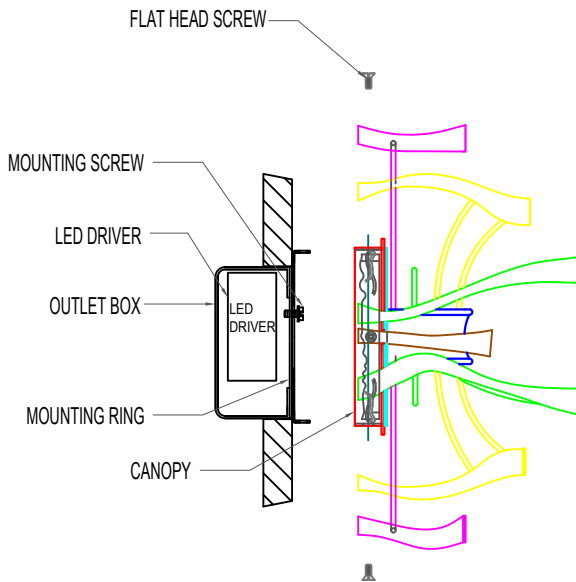

FIGURE-2